

CMD-J7

SERVICE MANUAL

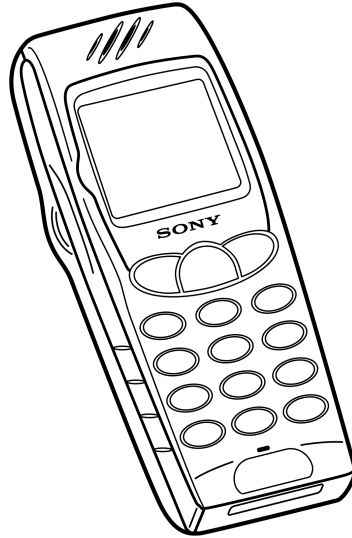

AEP-Model
UK-Model

SPECIFICATIONS

Signalling format	Dual-Band
Frequency range	E-GSM 900 MHz, Transmit: 880 ~ 915 MHz Receive: 925 ~ 960 MHz GSM 1800 MHz, Transmit: 1710 ~ 1785 MHz Receive: 1805 ~ 1880 MHz
GSM 900 power class	Class 4 (2W)
GSM 1800 power class	Class 1 (1W)
SIM	3V and 5V Pluggable mini SIM card / SAT Class 2
Display	High resolution full graphics display 4 Grey-scale type Resolution: 96 x 92 pixels 7 lines (excluding 1 status icon line), proportional font
Channel spacing	200 kHz
Number of channels	E-GSM 900: 174 GSM 1800: 374
Frequency stability	Transmit frequency drift (synchronized) < ± 0,1 p.p.m
RF output power	E-GSM 900: 2W, 33dbm GSM 1800: 1W, 30dbm
Antenna type	Patch antenna
Battery	Lithium Ion / 800 mAh Standby : 60 -330 h (Network dependent) Talk time : 2.5 - 9 h (Network dependent)
Dimensions	113 mm x 44.4 mm x 21.5 mm ³
Weight	92 g
Volume	82 cm ³

**PORTABLE DIGITAL CELLULAR TELEPHONE
WITH ACCESSORIES**

SONY®

Power requirements	3.9 V (nominal)	
Operating temperature	-20°C to +55°C	
Accessories operating temperature	± 0°C to +45°C	
Connectors	External RF connector Universal Connector (12-pin flat I/O connector) Mini plug head set jack	
WAP	Supported by the WAP v.1.1 compliant browser WTLS Class 1, HTTP/HTML	
Email	Supported by the e-mail protocols: SMTP & POP 3	
Supplied accessories	AC Adapter	QN-3AC1 (AEP)
	AC Adapter	QN-3AC2 (UK)
	Battery	QN-J7BPS
Optional accessories	Handsfree Car Kit	QN-3HFK
	Car Phone Holder	QN-J7PH
	Cigar Lighter Charger	QN-3CC
	Data Cable RS	QN-3RS
	Data Cable USB	QN-3USB
	Mobile Data Software	QN-3DS
	Headset	QN-3HS
	Travel Charger	QN-3TC

Design and specifications are subject to change without notice.

© by]CC[Toko

NOTE

This device contains electrostatically sensitive components. Damage can occur to these components if the appropriate handling is not adhered to.

ESD Handling precautions:

A working area in which Digital Cellular Telephones may be safely handled without undue risk of damage from electrostatic discharge must be available.

The area must be equipped as follows:

- All working surfaces must have a dissipative bench mat, safe for use with live equipment, connected via 1.2M Ω resistor to a common ground point.
- A quick release skin contact device with a flexible cord, which has a built-in safety resistor of a range between 5.2K Ω and 1.2M Ω shall be used. The flexible cord must be attached to a dissipative earth point.
- All containers and storage must be of the conductive type.

Batteries:

This device contains an internal battery in addition to the external battery pack. These batteries are recyclable and should be disposed of in accordance with national legislation. They must not be incinerated, or disposed of as ordinary rubbish.

CAUTION

Danger of explosion if battery is incorrectly replaced.
Replace only with the same or equivalent type recommended by the manufacturer.
Discard used batteries according to the manufacturer's instructions.

ADVARSEL!

Lithiumbatteri-Eksplosjonsfare ved feilagtig håndtering.
Udskiftning må kun ske med batteri af samme fabrikat og type.
Levér det brugte batteri tilbage til leverandøren.

VAROITUS

Paristo voi räjähtää, jos se on virheellisesti asennettu. Vaihda paristo ainoastaan laitevalmistajan suosittelemaan tyyppiin.
Hävitätä käytetty paristo valmistajan ohjeiden mukaisesti.

WARNING

Explosionsfara ved feilaktigt batteribyte.
Använd samma batterityp eller en likvärdig typ som rekommenderas av apparattillverkaren.
Kassera använt batteri enligt gällande föreskrifter.

ADVARSEL

Ekspløsjonsfare ved feilaktig skifte av batteri.
Benytt samme batteritype eller en tilsvarende type anbefalt av apparatfabrikanten.
Brukte batterier kasseres i henhold til fabrikantens instruksjoner.

TABLE OF CONTENTS

SECTION 1

Specifications	(see Cover sheet)
----------------------	-------------------

SECTION 2

General Descriptions

2.1 Multi Band	04
2.2 Radio Frequency Power Level	05
2.3 Speech Codec	05
2.4 Languages	05
2.5 Battery Charging	06
2.6 Battery Safety	06
2.7 Battery Capacity	06
2.8 Accessory Interface	07

SECTION 3

Operating Instructions

3.1 Basic Features	08
3.2 Security Codes	09
3.3 Icon Glossary	10
3.4 Menu Overview	10
3.5 Applications Menu	10

SECTION 4

Disassembling/Testing

4.1 Disassembly	11-12
4.2 Interface to GSM-Tester	13
4.3 Jigs and Tools.....	14

SECTION 5

Programming Instructions

5.1 Requirement	15
5.2 Hardware Set-up	15
5.3 Software Set-up	15
5.3.1 Software Download to Mobile	15-16
5.3.2 Save Personal Data in Mobile	16
5.3.3 Reset of Personal Data	16
5.3.4 Reset of Security Lock	16

SECTION 6

Explosion View

6.1 Spare Parts List	17
6.2 Accessories	18

SECTION 2

GENERAL DESCRIPTIONS

2.1 Multi-band :

CMD-J7 support E-GSM 900 and GSM 1800 multi-band functionality.

For the use in Europe and in other countries worldwide, ETSI has specified GSM standards into two frequency bands. That is the 900-MHz and 1800-MHz band and is usually referred to as GSM900 and GSM1800 (formerly DCS1800).

While the 900-MHz band has 124 channels (extended version: 175), the 1800-MHz band with its 375 channels provides a three-times higher capacity. Not only as a result of this large range of channels but also due to the low transmission power and the transmission distance, GSM1800 supports a higher quantity of RF-channels.

The Dual band technology enables a network operator with spectrum at both 900MHz and 1800MHz to support the seamless use of dual band handsets across both frequencies. By supporting seamless handovers between 900MHz and 1800MHz, Dual band networks can provide major benefits in terms of capacity enhancement and revenue optimisation through the introduction of new services.

The CMD-J7 is a phase II, GSM900 class 4, GSM1800 class 1 mobile phone.

The nominal maximum output power for GSM900 is 2W, for GSM1800 1W.

It supports the extra functionality required for multi-band mobile stations: Inter-band/"seamless" hand-over, channel assignment, cell selection and re-selection, all between both bands within a **Public Land Mobile Network**. The manual and automatic PLMN selection in both bands is given.

The user does not need any special action to use the multi-band functionality of the phone.

Users are able to manually roam between PLMN's operating in GSM900 and GSM1800 bands.

E-GSM

With the further development of the GSM standard, an additional range of frequencies has been made available to the "Global system for mobile communications". For each of the two duplex frequency ranges, one for the forward direction and one for the reverse direction, additional 10 MHz have been added to the bottom end of the bands, extending the frequency range to 50 further channels.

The mobile station transmits in the 880- to 915 MHz range, and the base station transmits in the 925- to 960 MHz range. A duplex spacing of 45 MHz is used, the base station always transmits on the high side of the duplex frequency pair.

The numbering for these additional channels is from 974 to 1023. This is done to avoid assigning one channel number twice within the same standard.

Compared to the primary GSM system, Channel number 0 is used in the extended GSM system, since it does not make sense to reserve it at a guard band within the E-GSM bands. Now, the lowest channel, number 974 (880.0 MHz), serves as the guard band between GSM and other services on lower frequencies.

GSM 1800

GSM1800 uses the frequency ranges of 1710 to 1785 MHz in the uplink direction, and 1805 to 1880 MHz in the downlink direction.

From these figures it follows that the duplex spacing is 95 MHz with 374 channels with bandwidths of 200 kHz each.

The channels are numbered from 512 to 885 in order to distinguish them from the channels in the primary and extended GSM frequency bands.

2.2 Radio Frequency Power Levels:

Between the GSM1800 and the E-GSM900 System are differences regarding the power level. GSM1800 basically needs lower power levels. If the performance of a MS for GSM system was certified of 2W (Power Class 4), then in the GSM1800 system it is only 1W (Power Class 1). There are also reduced BTS power levels due to microcell applications, which means instead of the 40W (Power Class 4) in the GSM 900 system, GSM1800 needs only 20W (Power Class 1).

Preferences	GSM 900	E-GSM	GSM 1800
Frequency band uplink: downlink:	MHz 890 - 915 935 - 960	MHz 880 - 915 925 - 960	MHz 1710 -1785 1805 - 1880
Radio Channels	124	174	374
max. BS-Power	40 W (46 dBm)		20W (43 dBm)
max. MS-Power	2 W (33 dBm)		1W (30 dBm)

2.3 Speech Codec

The CMD-J7 supports the following speech codecs.

- *Full Rate (FR) Codec*
- *Half Rate (HR) Codec*
- *Enhanced Full Rate (EFR) Codec*

The speech codec forms the human voice into a digital signal, which is sent in the GSM network.

The GSM system currently has three different speech codec standards.

At first, the Full Rate (FR) Codec was introduced. With new requirements concerning speech quality and availability of radio channel resources two further standards were introduced, the Half Rate (HR) Codec and the Enhanced Full Rate (EFR) Codec. The Half Rate (HR) Codec requires only half the channel capacity of a Full Rate (FR) Channel. The Enhanced Full Rate (EFR) Codec requires the same radio channel resources as a Full Rate (FR) Codec but offers Fixed Line quality with superior vocal clarity.

2.4 Languages

The CMD-J7 supports the following languages:

• Bulgarian	• French	• Portugese
• Croatian	• German	• Romanian
• Czech	• Greek	• Russian
• Danish	• Hungarian	• Slovakian
• Dutch	• Italian	• Slovenian
• English	• Norwegian	• Spanish
• Finnish	• Polish	• Swedish
		• Turkish

2.5 Battery Charging

There is no charging circuitry in the battery pack. The CMD-J7 has complete charger function internally.

The telephone can be charged only with the battery connected the phone. This situation can be sub-divided into two situations: the phone is on or off. It can be charged with the AC Adapter, Travel Charger or Cigar Lighter Charger.

The battery symbol is used to indicate the charging, and to indicate when the battery is fully charged. This is done using the following sequence of icons:



The uncharged segments of the battery are moving in a right to left manner until the charging stops. The sequences for each charging level is repeated until the battery is charged to that level.

When the charging sequence is finished the flashing of the battery level sign stops. The phone shows the full-battery icon.

2.6 Battery Safety

The battery pack contains a single Li-ion cell, a safety circuitry and, in addition, a microprocessor unit which manages RTC information by reading out the binary counter value in the microprocessor. The charging circuitry and the safety circuitry together guarantee a double fail-safe battery pack. This means that each component can be either short or open and still all the safety requirements will not be violated.

The safety concept protects against:

Over voltage: The charging is stopped when Battery Voltage (Vbat) reaches 4.25V- 4.3V. The charging resumes when Vbat falls below (4.025V - 4.125V).

Under voltage: When the cell voltage drops below 2.242V – 2.358V the cell is disconnected for discharging. Charging is still possible.

Current fuse: Finally, if all protection functions are out of order due to abnormal condition, the current fuse protects the device from explosion and fire with melting. The fuse melts 10A during 1 second.

2.7 Battery Capacity

QN-J7BPS 800mAh, Li-ion

The phone can be charged even during making phone calls. However, the shortest charging time will be reached when the phone is switched off.

2.8 Accessory interface

The table explains what kind of pins the phone supplies to the different accessories.

Pins	GND 1	Charge 2	GEN I/O 3	Power OUT 4	RX (IN) 5	TX (OUT) 6	ACC ID 7	RS232 RTS 8	RS232 CTS 9	Audio Out 10	Audio IN 11	AGND 12
Charger	√	√										
CLC	√	√										
HFK	√	√		√			√			√	√	√
Data Cable RS	√		√	√	√	√	√	√	√			
Data Cable USB	√		√	√	√	√	√	√	√			

Connector layout

Connector view from base of phone

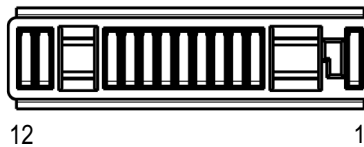

The connector comprises the following pins:

Audio

Audio In, Audio Out and Audio GND:

Audio IN:

Is a single ended input with a maximum sensitivity of 365 mVrms.

Audio OUT:

The single ended output delivers 0.8Vpp into a 1kΩ load.

These two signals are referred to as AGND.

RS232 Interface

5-pin interface: RX, TX, RTS(RFR), CTS and Gen I/O(DTR or DCD):

This is the communication interface to the Data cable “QN-3RS/USB”.

Pin 3 is connected to a general IO pin on the baseband digital chip. The functionality can be assigned on an accessory by accessory basis to be input, output or interrupt.

Charge

The Charge pin represents the positive contact for the charging functionality.

GND

The Ground pin represents the digital interface and charger return current.

ID

This pin shows the presence of an accessory and is also an analog ID for the accessory. Accessories which provide charger functionality only, do not support this pin and their presence is detected with a valid charger voltage.

Power Out

Power-out has a different functionality with different accessories.

In the car-kit environment the ext. Vbat indicates that a phone call is accepted/in progress. This information is used by the car-kit to power up the audio section of the car-kit, mute the car stereo and keep the car-kit powered up even when the ignition is switched off.

Due to the fact that the ID of the accessory is detected first, the ACC power is not current limited (protected).

SECTION 3 OPERATING INSTRUCTIONS

3.1 The Basic Features of the CMD-J7

• Parts and Controls

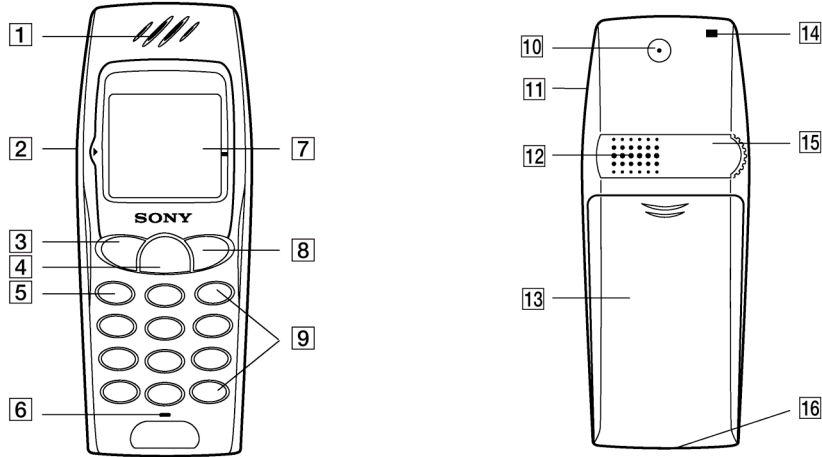

This section provides a brief guide to the operation and facilities available on the CMD-J7. Refer to the Operating Manual for full operational information.



- | | |
|---|---|
| <p>1 Ear piece</p> <p>2 Jog Dial</p> <p>3 Send Key</p> <p>4 Centre Key</p> <p>5 Voice Mail Key</p> <p>6 Microphone</p> <p>7 Display</p> <p>8 On/Off Key, Call End Key</p> | <p>9 Keypad (Alphanumeric Keys)</p> <p>10 External Antenna Connector</p> <p>11 Headset Connector</p> <p>12 Loudspeaker</p> <p>13 Battery Cover</p> <p>14 Hand Strap Attachment</p> <p>15 Finger Stop</p> <p>16 External Connector</p> |
|---|---|

• Jog Dial

The Jog Dial provides fast and easy menu navigation with only one hand.

Operation Function	Function	
Rotate the Jog Dial clockwise or counter-clockwise		Scrolls through menu options. Opens Phonebook in Standby Mode.
Press the Jog Dial straight into the phone		Opens Menu in Standby Mode. Selects an option (highlighted in the display)
Press and hold		Dials the phone number selected.

• The Centre Key

- ❖ Press the Centre Key in standby mode to access the WAP mode if WAP settings are configured.
- ❖ During a call, press the Centre Key to access the Call Menu.
- ❖ Press and hold the Centre Key to access network-specific service (SIM Application Toolkit)
This feature is dependent on your network operator and may not be supported by some networks.





- **Loudspeaker**

- ❖ During a call, press the Centre Key and select Loudspeaker to turn the Loudspeaker on/off.



- **The Voicemail Key**

- ❖ Press and hold  to access your Voicemail.

- **Manner Mode**

- ❖ In standby mode, press and hold  to activate/deactivate the manner modes..
- ❖ Afterwards, it is possible to switch among the manner mode functions. All manner mode icons appear in the display; rotate the Jog Dial to select one:
 - Silent Mode : turns the ringer and all tones to silent mode.
 - Ringer to Single beep : ringer is restricted to a discrete single beep.
 - Vibra Alert : Vibra Alert without the ringer.
- ❖ For your convenience, pressing and holding  in standby mode will toggle between the two last settings.
- ❖ During an incoming call, stop the ringer by pressing the Centre Key.
- ❖ During a game, stop/start the background sound by pressing the Centre Key.

- **Keypad Lock**

- ❖ In standby mode, press the Centre Key followed by  to lock/unlock your keypad (including Jog Dial). It is still possible to make emergency calls (112) as well as answer/reject an incoming call (by pressing  / ) when the keypad is locked.

3.2 Security Codes

CODE TYPE	NUMBER OF DIGITS	DESCRIPTION
PIN Personal Identification Number	4 to 8	Controls SIM security. Supplied by the Service Provider !
PIN 2	4 to 8	Controls memory security. Supplied by the Service Provider !
PIN / PIN 2 Personal Unblocking Key (PUK / PUK 2)	8	Used to unblock PIN and PIN 2. A PIN or PIN 2 will become blocked if the wrong PIN or PIN 2 is entered three times. When the blocked PIN or PIN 2 is unblocked, a new PIN or PIN 2 must be entered. If the wrong PUK or PUK 2 is entered 10 times, the SIM card will be unusable. Supplied by the Service Provider !
Bearing Password	4	Controls the call bar function. If the wrong password is entered three times, this service will be revoked. Supplied by the Service Provider !
Security Code	4 to 8	Controls the access to wap-and e-mail settings. The default Security Code is: 0000 Refer to Section 5 "Programming Instructions"

3.3 Icon Glossary

ICON	Explanation
	Network not available
	Network signal strenght (strong)
	Battery strength
	SMS (Envelope Icon)
	Voicemail
	Alarm
	Silent Mode
	Vibra Alert
	Single Beep
	Ringer off
	Conversation Privacy (ciphering) not supportet

ICON	Explanation
	Missed calls
	Incoming call barring
	Outgoing call barring
	Incoming + Outgoing call barring
	Conditional Divert
	Unconditional Divert
	Active call
	Call hold
	Mute Microphone
	Headset connected
	Handsfree Kit connected
	Loudspeaker on

3.4 Menu Overview

Press the Jog Dial from standby mode to access the Main menu:

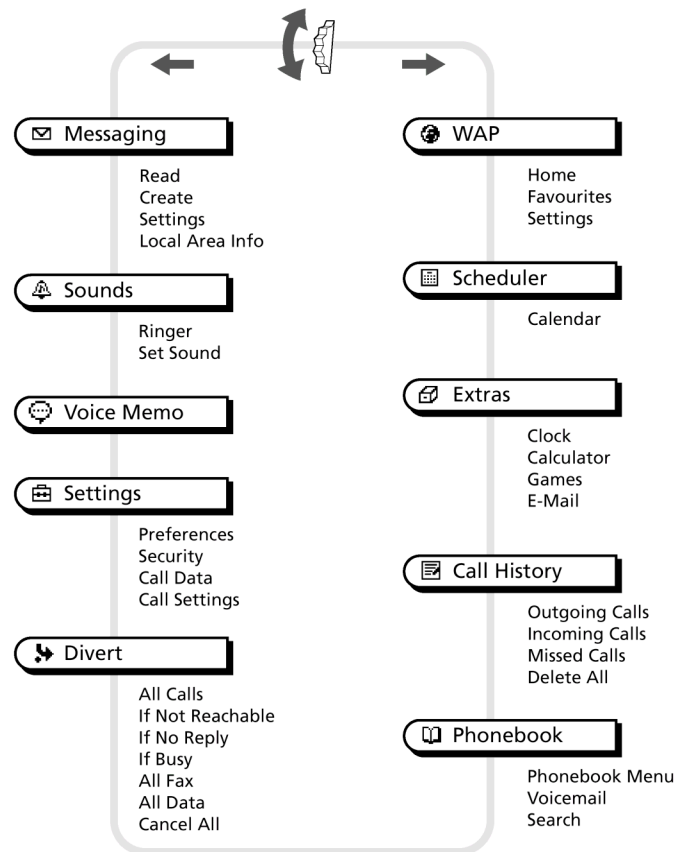

SECTION 4 DISASSEMBLY

IMPORTANT NOTE :

The IMEI number is the electronic identification of the hardware, which is stored electronically. There should be no discrepancy between the number on the sticker and the number within the set memory allowed.

In case of replacing the lower cabinet it is to make sure that the IMEI Sticker mounted on the lower case (visible from the battery compartment) will be replaced to the new housing part as well.

Follow the disassembly procedure in the numerical order given.

CABINET (UPPER & LOWER)

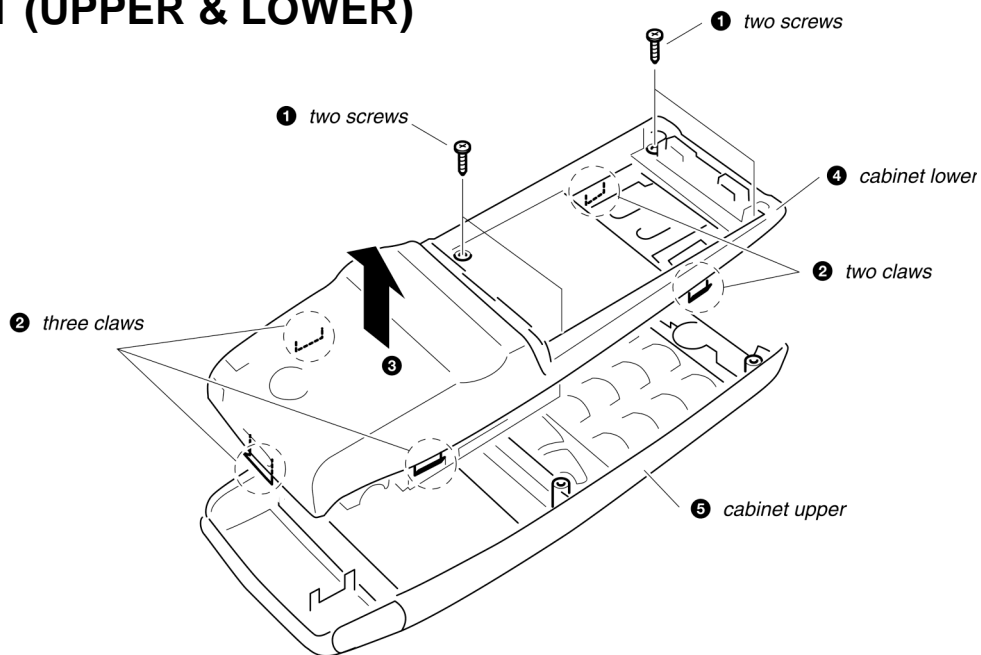

MAIN BOARD ASS'Y

IMPORTANT:
Do not detach the shield case from the main board

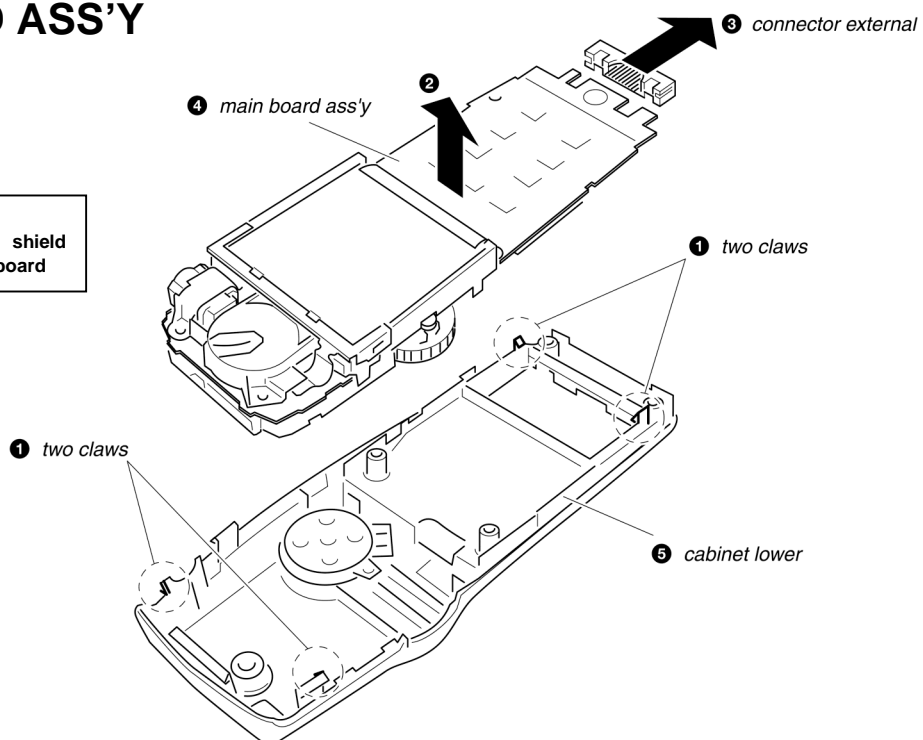

LCD ASS'Y & ANTENNA

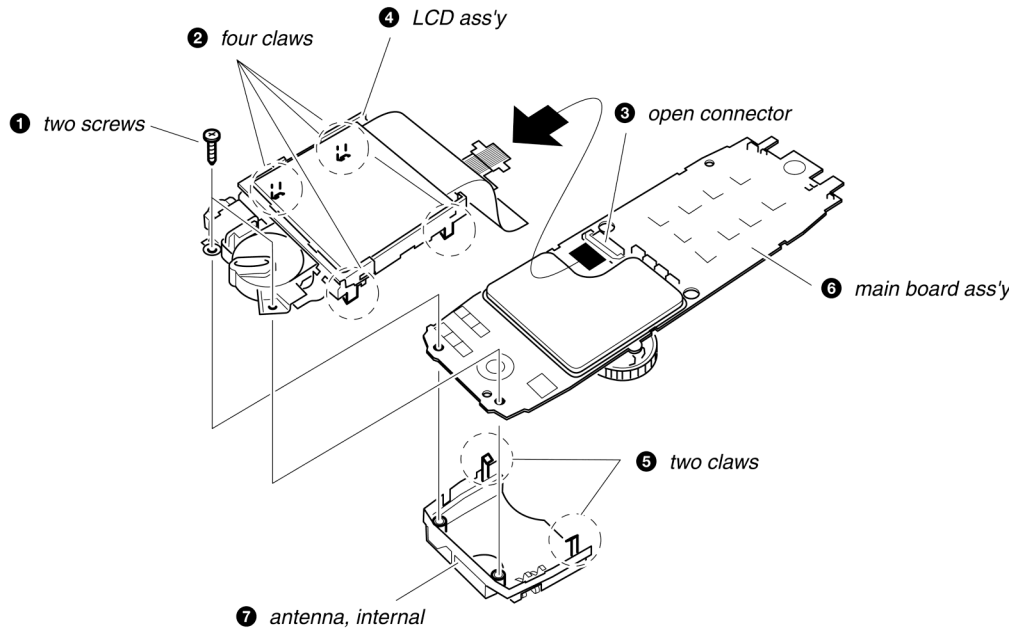

LCD MODULE

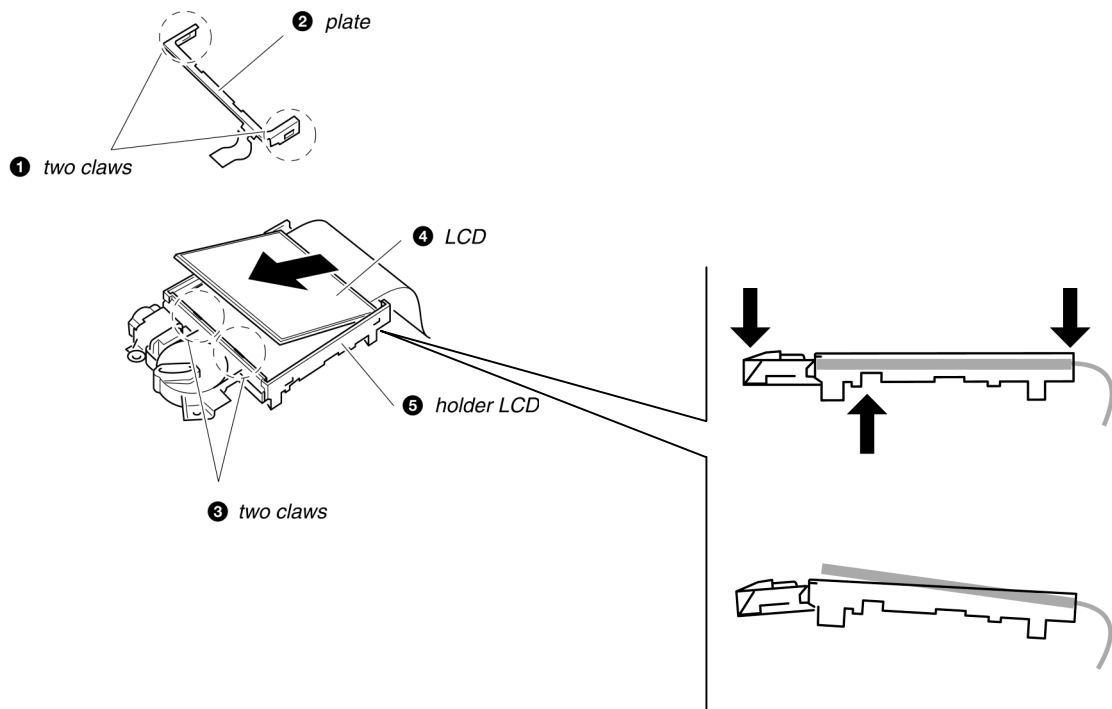

Re-assembly procedure :

To re-assemble the unit, apply the reverse order of the above mention disassembly procedure.

4.2 Interface to GSM-Tester

Test Set Up for CMD-J7 Level 1 Testing

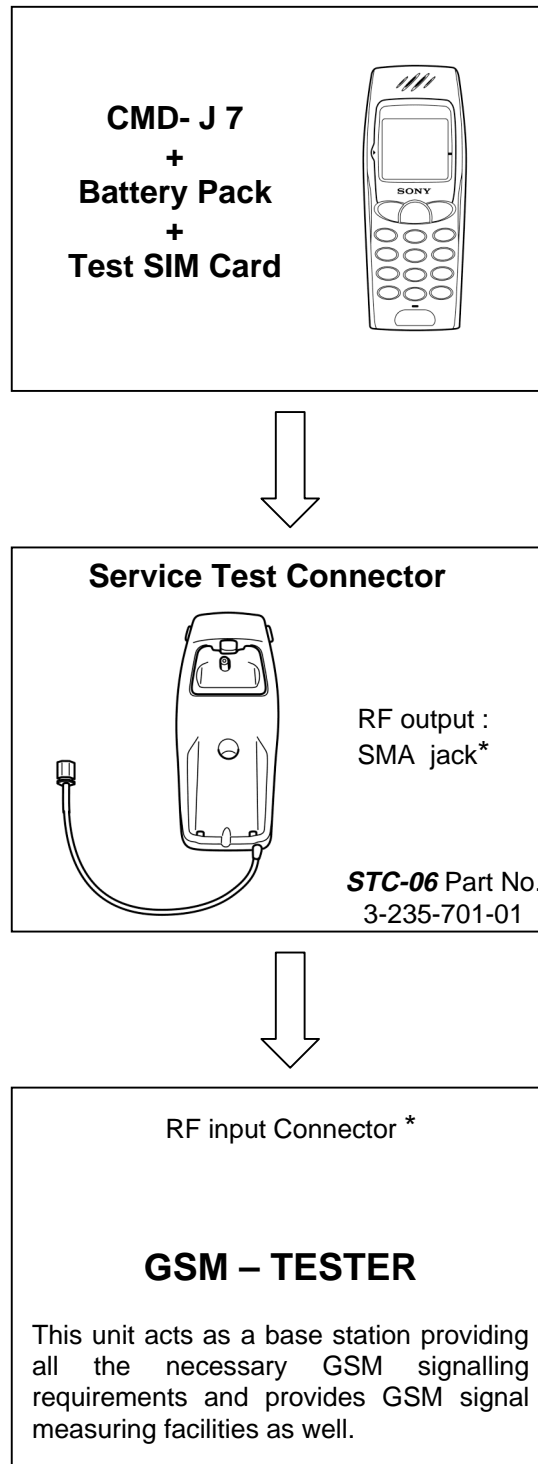

* Use special RF-Adapter for connection of **STC-06** to your GSM –Tester !

Level Test Procedure with GSM TESTER recommendation:

- Simulate GSM call processing – to check the functionality of transmitting and receiving audio signals of loudspeaker and microphone.
- Basic GSM transmission & reception parameter testing – to ensure that handset's performance compiles with standard GSM specification.

4.3 Jigs & Tools

Description	Part No	Remark
DATA TRANSFER CABLE <i>DTC-04</i>	1-757-348-11	Necessary For Software Update
HOOK RELEASE JIG	3-043-180-01	For Housing Opening
SERVICE TEST CONNECTOR <i>STC-06</i>	3-235-701-01	For Connection To GSM Measure Equipment

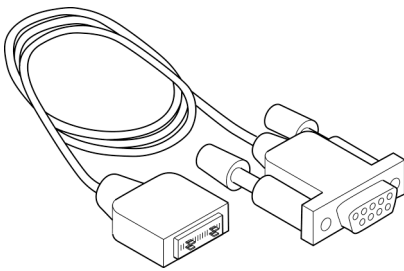

DATA TRANSFER CABLE

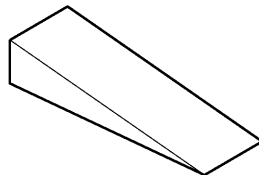

HOOK RELEASE JIG

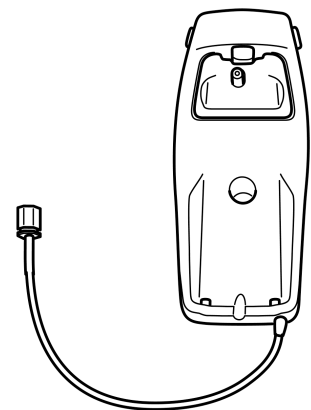

SERVICE TEST CONNECTOR

Section 5

PROGRAMMING INSTRUCTIONS

5.1 Requirement

- PC (486 type or higher) with Microsoft "Windows" Operating System
- One COM-port free for usage
- The Data Transfer Cable (p/n 1-757-348-11)

PREPARATION FOR SOFTWARE UPDATE

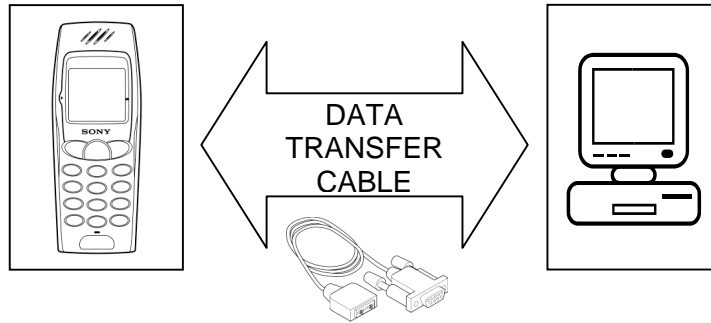

5.2 Hardware set-up

- Copy all the files to the PC (define own directory).
- Connect the Data Transfer Jig to the PC COM-port (COM 1 or COM 2) and the CMD-J7 external connector.
- Insert a test SIM in the CMD-J7; this is because during the procedure the Flash Loader will attempt to perform data control operations, which are not generally permitted by original SIMs. The test SIM is not absolutely necessary for a generally software update, although it is useful.
- Attach battery pack to CMD-J7; the CMD-J7 is powered up from the battery pack.
- The initial settings of the flash.exe program may not correspond with the normally correct settings. It is highly advisable to check the settings first (see 5.3 Software set-up).

5.3 Software set-up

5.3.1 * *Download Software to Mobile (Software Update)*



- Start the program flash.exe by double-clicking on its icon in the Windows Explorer. J7/J70 Flash.exe

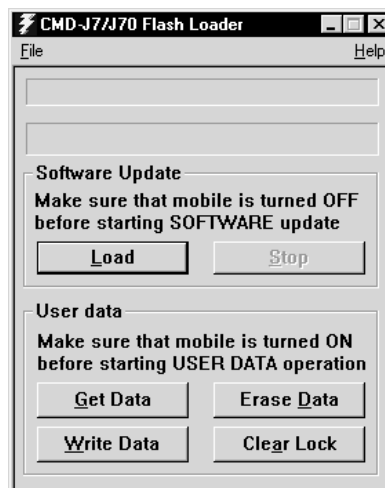

- Select “file”/”Settings...” and check if the settings for the “Com Port” and “Speed” are correct.

- The FlashLoader automatically detects all available Com ports on the PC. (COM 1 or COM 2)
- Baud rates up to 812500bps will be supported, but standard PCs, unless it is correctly customised (i.e. with a Fast Serial Board), will not support Baud rates > 115200bps.

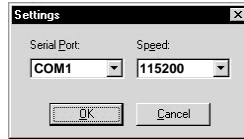

- The default values are

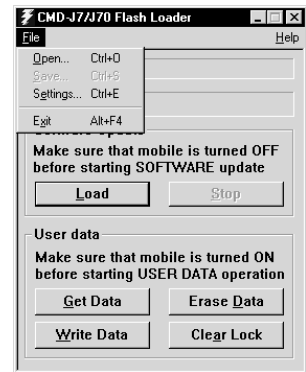

- Click on the “Load” button and select an SRE file for downloading.
 - The CMD-J7 software is located in the J7.SRE file.
 - Any other SRE file is either only needed for the program itself, or can be a personal data file.

Note: If a “flash.sre” file appears, please mind that this is application software (do not use / modify)

- Switch on the CMD-J7.
- Now the program runs automatically.

5.3.2 * Save User Data in Mobile (Get Data / Write Data)

- Check if the settings for the “Com Port” and “Speed” are correct.
- Switch on the CMD-J7.
- Click on “Get Data”.
- Now the program runs automatically (if the application does not start after a while, press any key of the CMD-J7)
- After the read data is downloaded, either reload it in another mobile (reconnect a new mobile and click on “Write Data”) or save it on the disc using File/Save option.
- When the message “write user data complete” appears, disconnect the Data Transfer Cable and make sure that the attached battery pack will be removed (do not switch off the terminal with the ON/OFF key).

5.3.3 * Reset of User Data (Erase Data)

- Check if the settings for the “Com Port” and Speed” are correct.
- Switch on the CMD-J7.
- Click on “Erase Data”.
- Now the program runs automatically, all individual settings (such as Phonebook entries and WAP settings etc.) will be deleted.
- When the message “erase user data complete” appears, disconnect the Data Transfer Cable and make sure that the attached battery pack will be removed (do not switch off the terminal with the ON/OFF key).

5.3.4 * Reset of Security Code Lock (Clear Lock)

- Check if the settings for the “Com Port” and Speed” are correct.
- Switch on the CMD-J7.
- Click on “Clear Lock”.
- The individual Security Code will be reset to the default setting: 0000 !

For any of the above stated functions, follow the instructions written in the status bar (the first one from the top).

Follow up the progress of the up/download process by checking the Progress bar (the second one from the top).

Note: Do not forget to remove the test SIM before returning an intact mobile phone.

SECTION 6 SPARE PARTS AND ACCESSORIES LIST

6.1 Spare Parts

Note:

- The parts with no reference in the exploded view are not supplied.

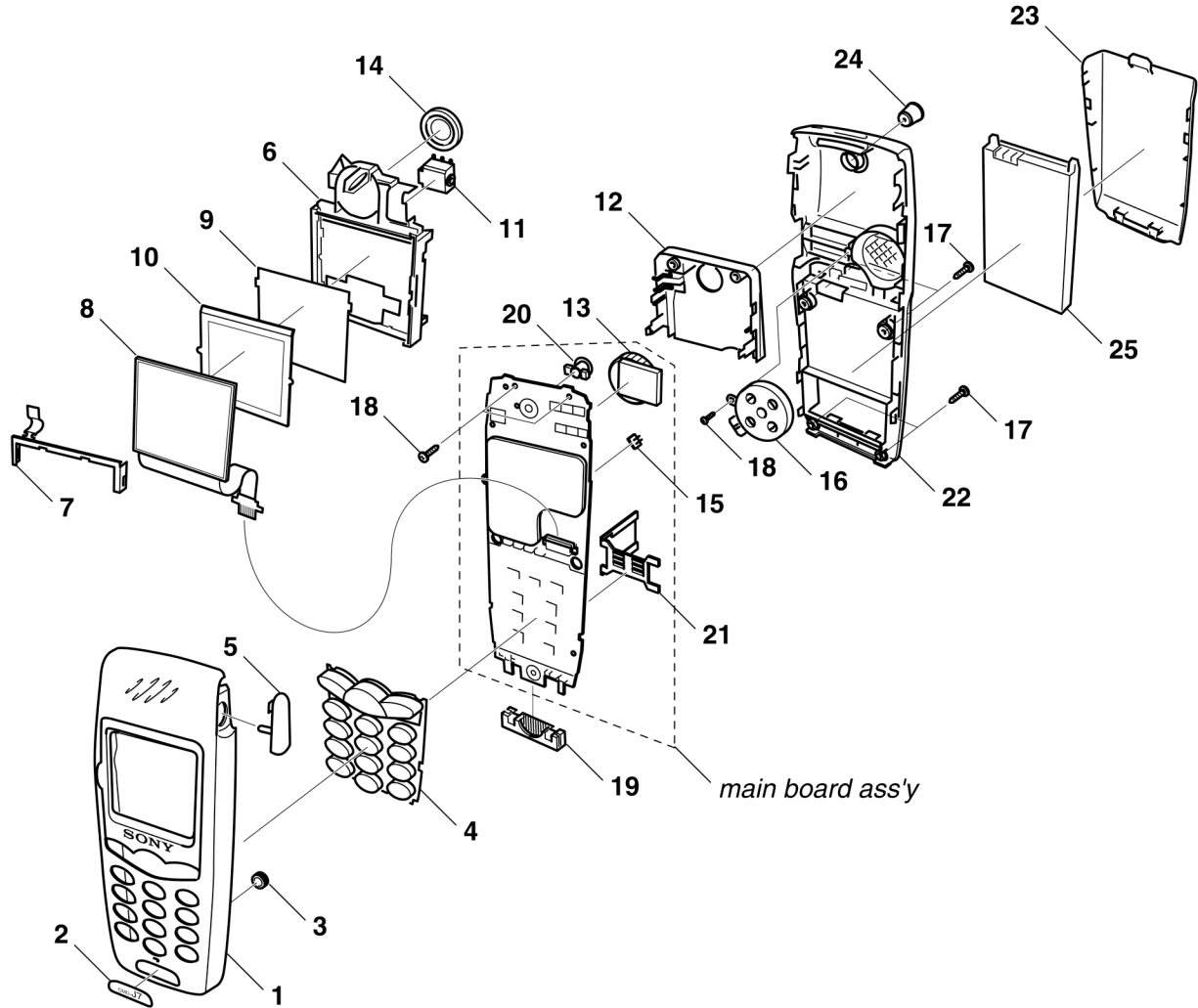

<u>Ref. No.</u>	<u>Part No.</u>	<u>Description</u>	<u>Remark</u>	<u>Ref. No.</u>	<u>Part No.</u>	<u>Description</u>	<u>Remark</u>
1	A-3649-336-A	CABINET, UPPER		16	1-544-887-11	MULTIACTOR	
2	3-231-502-01	BADGE, PRINTING		17	3-929-548-01	SCREWS	1.7x6
3	1-542-441-21	MICROPHONE		18	3-933-455-01	SCREWS	1.4x4
4	3-231-511-01	KEYPAD		19	1-815-606-11	CONNECTOR EXTERNAL	
5	3-234-747-01	CAP, JACK		20	1-794-622-21	CONNECTOR COAXIAL	
6	3-233-423-01	HOLDER, LCD		21	1-793-605-22	SIM CONNECTOR	
7	3-234-748-01	PLATE, SAR		22	3-232-516-01	CABINET, LOWER	
8	1-804-463-11	LCD MODULE		23	3-231-501-01	LID, BATTERY	
9	3-233-425-01	SHEET REFLECTION		24	3-233-437-01	CAP, RF	
10	3-233-424-01	GUIDE, LIGHT		25	1-756-203-11	BATTERY PACK	
11	1-815-608-41	JACK, HEADSET					
12	1-754-217-11	ANTENNA, INTERNAL					
13	1-418-057-24	JOG SWITCH					
14	1-251-898-41	RECEIVER					
15	1-815-730-21	CONNECTOR, MULTIACTOR					

6.2 Accessories

<u>Ref. No.</u>	<u>Part No.</u>	<u>Description</u>	<u>Remark</u>
101	1-476-203-12	ADAPTER, AC (AC-110-240V)	EU
	1-476-204-12	ADAPTER, AC (AC-110-240V)	UK
102	1-756-203-11	BATTERY PACK	
	3-233-649-13	MANUAL, INSTRUCTION	(ENGLISH)
	3-233-649-22	MANUAL, INSTRUCTION	(GERMAN)
	3-233-649-32	MANUAL, INSTRUCTION	(FRENCH)
	3-233-649-42	MANUAL, INSTRUCTION	(DUTCH)
	3-233-649-52	MANUAL, INSTRUCTION	(ITALIAN)
	3-233-649-62	MANUAL, INSTRUCTION	(SPANISH)
	3-233-649-72	MANUAL, INSTRUCTION	(PORTUGUESE)
	3-233-650-12	MANUAL, INSTRUCTION	(CZECH)
	3-233-650-22	MANUAL, INSTRUCTION	(POLISH)
	3-233-650-32	MANUAL, INSTRUCTION	(TURKISH)
	3-233-650-62	MANUAL, INSTRUCTION	(SWEDISH)

